



HIGH VOLUME SERVICE - SELF SERVICE - WIDE (FRONT) DELI / BAKERY
HUSSMANN - R3HV-WD, R3HV-WB / CR3HV-WD, CR3HV-WB

REVISION DATE

01/24/23



Hussmann refrigerated merchandisers configured for sale for use in the United States meet or surpass the requirements of the DOE 2017 energy efficiency standards.

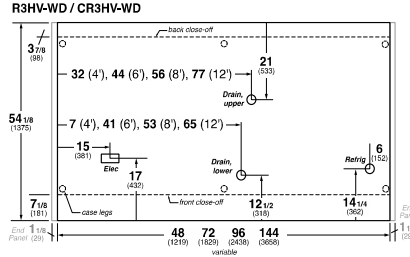
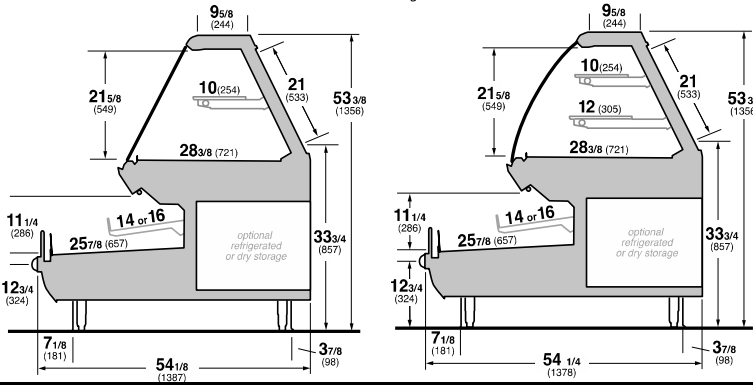
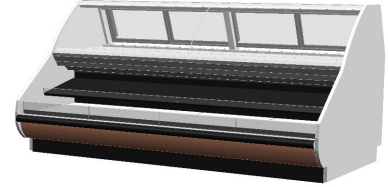

REFRIGERATION DATA:

CASE LENGTHS/ WEDGES	CASE USAGE	CAPACITY TOP/FRONT *** (BTU/HR/FT)		TEMPERATURE (°F)			VELOCITY (TOP/FRONT) (FT/MIN)
		RATING CONDITION		EVAPO-RATOR		DISCHARGE AIR (TOP/FRNT) **	
		NSF 7	AHRI 1200	NSF 7	AHRI 1200		
4', 6', 8', 10', 12'	DELI / BAKERY	280 / 740	180 / 490	20	24	26 / 30	150~175/175~200
REAR STORAGE	DELI / BAKERY	110	90	20	26	29	600~700

CASE LENGTHS	EST REFG CHRGR (R404A) (LBS)	20°F GLYCOL 6° RISE INLET TOP		20°F GLYCOL 6° RISE INLET FRONT		20° GLYCOL 6° RISE INLET OPTION REFRIGERATED REAR STORAGE	
		GPM	PSI	GPM	PSI	GPM	PSI
4'	1.3	0.4	0.7	1.1	2.7	0.2	0.1
6'	1.5	0.5	2.0	1.5	6.2	0.2	0.3
8'	2.0	0.7	3.7	2.0	2.9	0.3	0.5
10'	2.5	0.8	6.0	2.5	5.0	0.4	0.8
12'	3.1	1.0	8.7	3.0	5.8	0.5	1.1

**FRONT DISCHARGE AIR MEASURED INSIDE AIR CURTAIN HONEYCOMB

***REFRIGERATION NOTES:

- 1) BTU'S INCLUDE 2 ROWS (1 TOP; 1 FRONT) CANOPY LED LIGHTS AND NO SHELF LIGHTS
- 2) ADD 10 BTU'S PER FOOT/PER SHELF FOR OPTIONAL TOP LED SHELF LIGHTS
- 3) AHRI 1200 RATING POINT FOR ENERGY CONSUMPTION COMPARISON ONLY
- 4) USE DEW POINT FOR HIGH GLIDE REFRIGERANTS. CARE SHOULD BE TAKEN TO USE THE DEW POINT IN P/T TABLES FOR MEASURING AND ADJUSTING SUPERHEAT. ADJUST EVAPORATOR PRESSURE AS NEEDED TO MAINTAIN THE DISCHARGE AIR TEMPERATURE SHOWN.
- 5) RATING CONDITION IS NSF TYPE I, 75°F/55% RH

REFRIGERATION DATA CONTINUED:

LOCATION	ELEC. THERMOSTAT / AIR SENSOR SETTINGS			DEFROST TYPE	TIME (MIN)	DEFROST FREQUENCY (#/DAY)	TERM. TEMP (°F) AIR TEMP	DRIP TIME	DE-FROST WATER (LBS/ DAY/FT)	FAN BLADE DIA.	FAN BLADE PITCH
	USAGE	CUT IN (°F)	CUT OUT (°F)								
TOP	DELI / BAKERY	29	26	OFF TIME	40	4	34	NA	0.34	6.75"	15°
FRONT	DELI / BAKERY	31	28								
REFRIGERATED REAR STORAGE	DELI / BAKERY	37	36								

END PANEL WIDTH KEY

# OF END PNLS	END PNL WIDTH (IN.)	TOTAL ADDED LENGTH (IN.)
1	1.125	1.125
2	1.125	2.25

ELECTRICAL DATA:

STANDARD FANS, HEATERS, LED LIGHTS (115 VOLT)

CASE LENGTH	EVAPORATOR FANS: TOP / FRONT			EVAPORATOR FANS: REFRIGERATED REAR STORAGE			CANOPY LIGHTS LED (TOP / FRONT)		OPTIONAL LED SHELF LIGHTS (TOP / FRONT)		OPTIONAL LED 2ND SHELF (TOP)		MAX. LED LOAD (W/ ALL OPTIONS) TOP / FRONT		ANTI-SWEAT HEATERS		CONVENIENCE OUTLETS (OPTIONAL)		
	# OF EVAP FANS	AMPS	WATTS	# OF EVAP FANS	AMPS	WATTS	AMPS	WATTS	AMPS	WATTS	AMPS	WATTS	AMPS	WATTS	AMPS	WATTS	# OUTLETS	VOLTS	AMPS
4'	1/2	0.1/0.2	8/16	1	0.3	8.8	0.1/0.1	10/10	0.1/0.1	10/10	0.1	10	0.2/0.3	20/30	0.8	97	1	115	15
6'	2/3	0.2/0.4	16/24	1	0.3	8.8	0.1/0.1	15/13	0.1/0.1	15/13	0.1	15	0.2/0.3	30/41	1.3	147	1	115	15
8'	2/4	0.2/0.5	16/32	1	0.3	8.8	0.2/0.2	21/21	0.2/0.2	21/21	0.2	21	0.4/0.6	42/63	1.7	197	1	115	15
10'	3/5	0.4/0.6	24/40	1	0.3	8.8	0.2/0.2	26/26	0.2/0.2	26/26	0.2	26	0.4/0.6	52/78	2.1	247	1	115	15
12'	3/6	0.4/0.7	24/48	1	0.3	8.8	0.3/0.3	31/31	0.3/0.3	31/31	0.3	31	0.6/0.9	62/93	2.6	297	2	115	30

OPTIONAL HIGH OUTPUT LED LIGHTS (115 VOLT)

CASE LENGTH	CANOPY LIGHTS H.O. LED (TOP / FRONT)		OPTIONAL SHELF (TOP / FRONT)		OPTIONAL 2ND SHELF (TOP)		MAX. H.O. LED LOAD	
	AMPS	WATTS	AMPS	WATTS	AMPS	WATTS	AMPS	WATTS
4'	0.1/0.1	15/15	0.1/0.1	15/15	0.1	15	0.2/0.3	30/45
6'	0.2/0.2	26/26	0.2/0.2	26/26	0.1	26	0.4/0.5	52/78
8'	0.3/0.3	30/30	0.3/0.3	30/30	0.2	30	0.6/0.8	60/90
10'	N/A	N/A	N/A	N/A	N/A	N/A	N/A	N/A
12'	0.4/0.4	46/46	0.4/0.4	46/46	0.3	46	0.8/1.1	92/138